

Pile Cutters for use with Bonded Type 1 Cut-off (Type 41) or Diamond Wheels

56PC Series

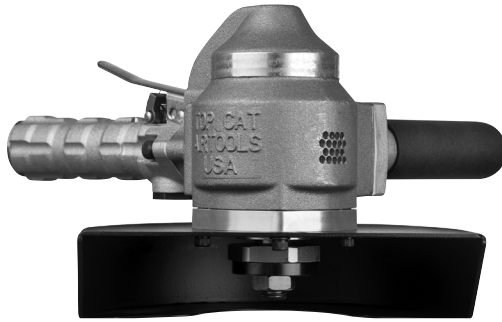

56PCK;6000;841

66PC Series



66PCK;4000;1441

Wheel Size	Rated Speed	Lever Style	MODEL NUMBER
8 Inch X 5/8 ID (200 mm)	6000 RPM	Standard Lever	56PCL;6000;841
		Safety Lever	56PCK;6000;841

Wheel Size	Rated Speed	Lever Style	MODEL NUMBER
10 Inch X 5/8 ID (250 mm)	6000 RPM	Standard Lever	66PCL;6000;1041
		Safety Lever	66PCK;6000;1041
12 Inch X 1.0 ID (300 mm)	5000 RPM	Standard Lever	66PCL;5000;1241
		Safety Lever	66PCK;5000;1241
14 Inch X 1.0 ID (350 mm)	4000 RPM	Standard Lever	66PCL;4000;1441
		Safety Lever	66PCK;4000;1441

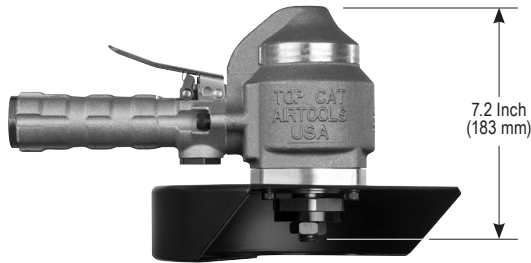

HP 3.0 H.P.
(2.3 kW)

cfm 25 cfm (18.8 L/s) Free Speed
60 cfm (28.3 L/s) Max

Lbs 11.3 Lbs.
(5.1 Kg)

SUPPLY 1/2" NPT Inlet
1/2" (13 mm) Hose Size

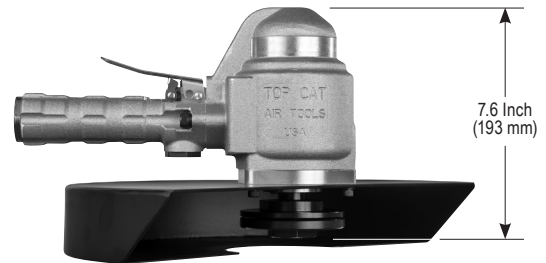

HP 4.0 H.P.
(3.0 kW)

cfm 25 cfm (18.8 L/s) Free Speed
75 cfm (35.4 L/s) Max

Lbs 15.8 Lbs.
(7.2 Kg)

SUPPLY 1/2" NPT Inlet
1/2" (13 mm) Hose Size

STANDARD EQUIPMENT

- Tool
- Operating Instructions and Service Manual
- Wrenches (sizes based on options)

ALTERNATE OPTIONS



WHEEL MOUNTING

